

DLCLRC

Installation Instructions

Outdoor Unit Single Zone Ductless System - Sizes 36 to 58



Fig. 1 —Size 36K



Fig. 2 —Sizes 48K - 58K

TABLE OF CONTENTS

	Page
SAFETY CONSIDERATIONS	2
INTRODUCTION	3
ACCESSORIES	3
DIMENSIONS	4
CLEARANCES	6
INSTALLATION REQUIREMENTS	7
INSTALLATION	7
Step 1 - Check Equipment	7
Step 2 - Mount Unit	7
Step 3 - Condensate Drain Installation	8
Step 4 - Refrigerant Piping	9
Step 5 - Evacuate Coil And Tubing System	12
Step 6 - Electrical Connections	13
WIRING	13
ELECTRICAL DATA	14
CONNECTION DIAGRAMS	14
START-UP	15
CARE AND MAINTENANCE	15
OUTDOOR UNIT DIAGNOSTIC GUIDES	15
DUCTLESS START-UP CHECKLIST	16

NOTES: Read the entire instruction manual before starting the installation.

Images are for illustration purposes only. Actual models may differ slightly.

SAFETY CONSIDERATIONS

Installing, starting up, and servicing air- conditioning equipment can be hazardous due to system pressures, electrical components, and equipment location (roofs, elevated structures, etc.).

Only trained, qualified installers and service mechanics should install, start- up, and service this equipment.

Untrained personnel can perform basic maintenance functions such as coil cleaning. All other operations should be performed by trained service personnel only.



When working on the equipment, observe the precautions in the literature and on tags, stickers, and labels attached to the equipment.

Follow all safety codes. Wear safety glasses and work gloves. Keep a quenching cloth and a fire extinguisher nearby when brazing. Use care in handling, rigging, and setting bulky equipment. Read these instructions thoroughly and follow all warnings or cautions included in literature and attached to the unit. Consult local building codes and National Electrical Code (NEC) for special requirements. Recognize safety information.

This is the safety- alert symbol . When you see this symbol on the unit and in instructions or manuals, be alert to the potential for personal injury. Understand these signal words: **DANGER**, **WARNING**, and **CAUTION**. These words are used with the safety- alert symbol. **DANGER** identifies the most serious hazards which will result in severe personal injury or death. **WARNING** signifies hazards which could result in personal injury or death.

CAUTION is used to identify unsafe practices which may result in minor personal injury or product and property damage. **NOTE** is used to highlight suggestions which will result in enhanced installation, reliability, or operation.

 WARNING	
ELECTRICAL SHOCK HAZARD Failure to follow this warning could result in personal injury or death.	
Before installing, modifying, or servicing system, main electrical disconnect switch must be in the OFF position. There may be more than 1 disconnect switch. Lock out and tag switch with a suitable warning label.	

 WARNING	
	EXPLOSION HAZARD Failure to follow this warning could result in death, serious personal injury, and/or property damage.
	Never use air or gases containing oxygen for leak testing or operating refrigerant compressors. Pressurized mixtures of air or gases containing oxygen can lead to an explosion.

 CAUTION	
EQUIPMENT DAMAGE HAZARD Failure to follow this caution may result in equipment damage or improper operation.	
Do not bury more than 36 in. (914 mm) of refrigerant pipe in the ground. If any section of pipe is buried, there must be a 6 in. (152 mm) vertical rise to the valve connections on the outdoor units. If more than the recommended length is buried, refrigerant may migrate to the cooler buried section during extended periods of system shutdown. This causes refrigerant slugging and could possibly damage the compressor at start-up.	

INTRODUCTION

The Horizontal Discharge Outdoor units are R-410A condensing units designed with application flexibility in mind. These units have a max total piping length up to 213 ft (65 m) and a maximum piping lift of up to 98 ft (30m).

The inverter driven compressor is designed to run at various input power frequencies (Hz) which controls the compressor’s motor speed.

ACCESSORIES

The system is shipped with the following accessories. Use all of the installation parts and accessories to install the system. Improper installation may result in water leakage, electrical shock and fire, or cause the equipment to fail. Keep the installation manual in a safe place and do not discard any other accessories until the installation work has been completed.

Table 1 —Accessories

PART NO.	PART NAME	QTY.
1	Outdoor unit	1
-	Literature package including installation instructions	1
-	Grommet to secure the outdoor unit (helps with vibration prevention during unit operation)	4
-	Drain Joint	1
-	Drain Hose	1

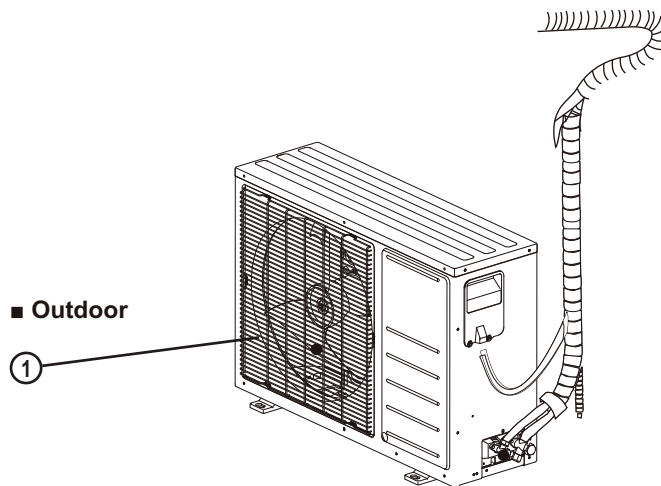

Fig. 3 —Parts List

NOTES:

- If the outdoor unit is higher than the indoor unit, prevent rain from flowing into the indoor unit along the connection pipe by making a downward arc in the connection pipe before it enters the wall to the indoor unit. This ensures that rain drips from the connection pipe before it enters the wall.
- Piping and the interconnecting wiring are field supplied.
- The illustration above is only a sketch. Different models may be slightly different.

Table 2 lists the units covered in this manual.

Table 2 — Unit Sizes

SYSTEM TONS	kBTUh	VOLTAGE - PHASE	OUTDOOR MODEL
3	36,000	208/230 - 1	DLCLRCH36AAK
4	48,000	208/230 - 1	DLCLRCH48AAK
5	58, 000	208/230 - 1	DLCLRCH58AAK

DIMENSIONS

Table 3 — Dimensions

UNIT SIZE		36K	48K	58K
Height	in (mm)	31.89 (810)	52.48 (1333)	52.48 (1333)
Width	in (mm)	37.24 (946)	37.48 (952)	37.48 (952)
Depth	in (mm)	16.14 (410)	16.34 (415)	16.34 (415)
Operating Weight	lbs (kg)	155.42 (70.5)	219.14 (99.4)	217.15 (98.5)
Shipping Weight	lbs (kg)	166.23 (75.4)	249.12 (113)	248.24 (112.6)
Shipping Height	in (mm)	34.45 (885)	34.45 (885)	34.45 (885)
Shipping Width	in (mm)	42.91 (1090)	42.91 (1090)	42.91 (1090)
Shipping Depth	in (mm)	19.69 (500)	19.69 (500)	19.69 (500)

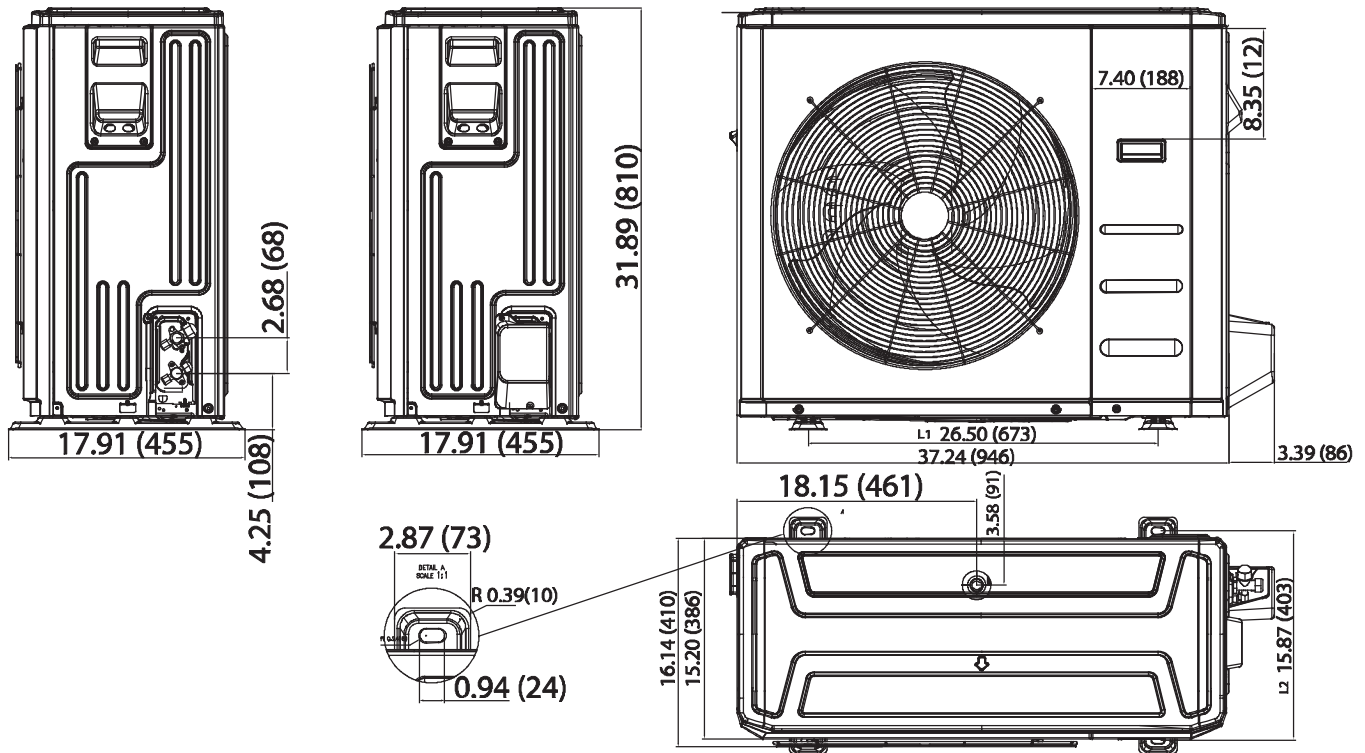

Fig. 4 — Size 36K

DIMENSIONS (CONT.)

Sizes 48K - 58K

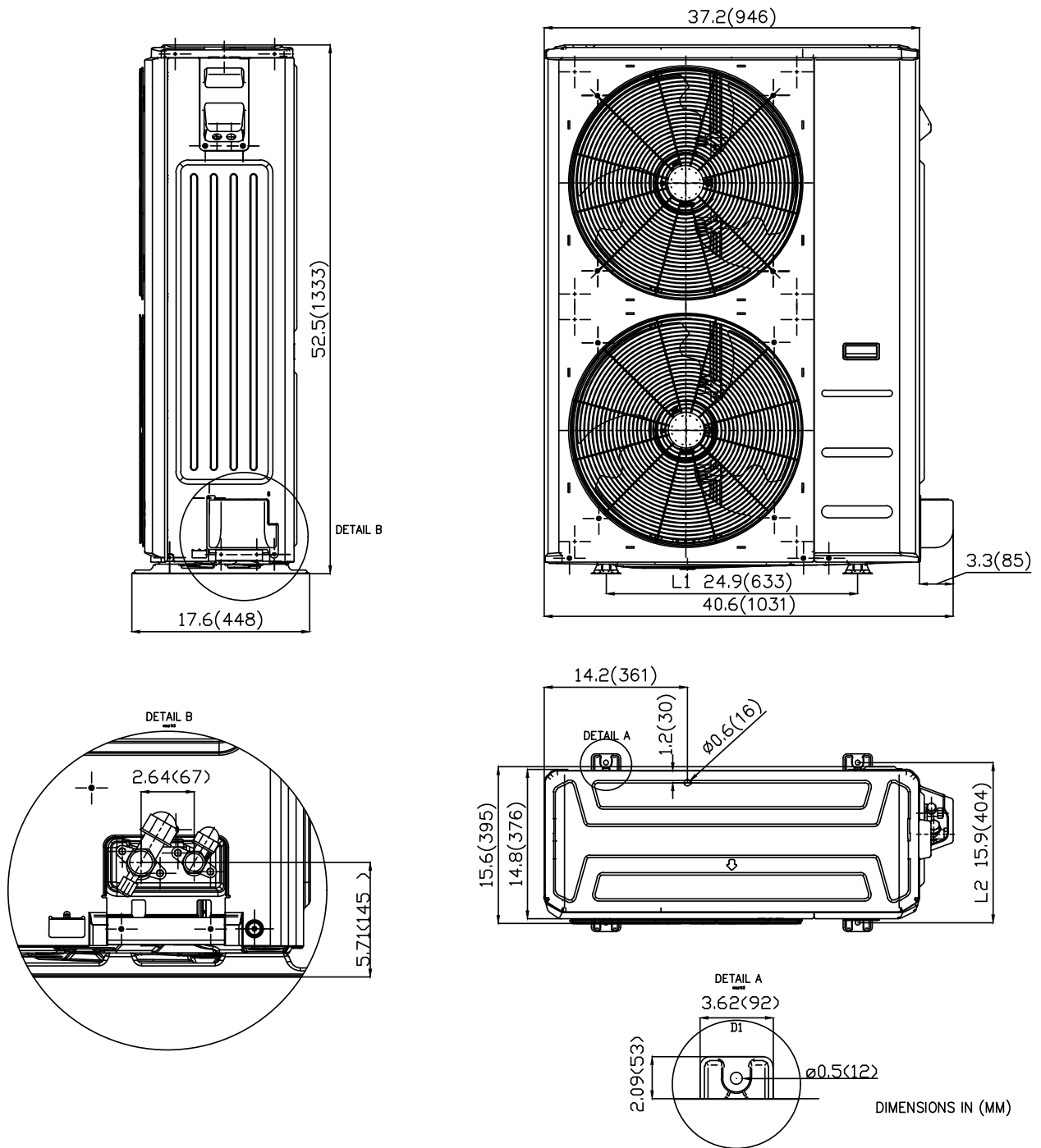

Fig. 5 — Sizes 48K - 58K

CLEARANCES

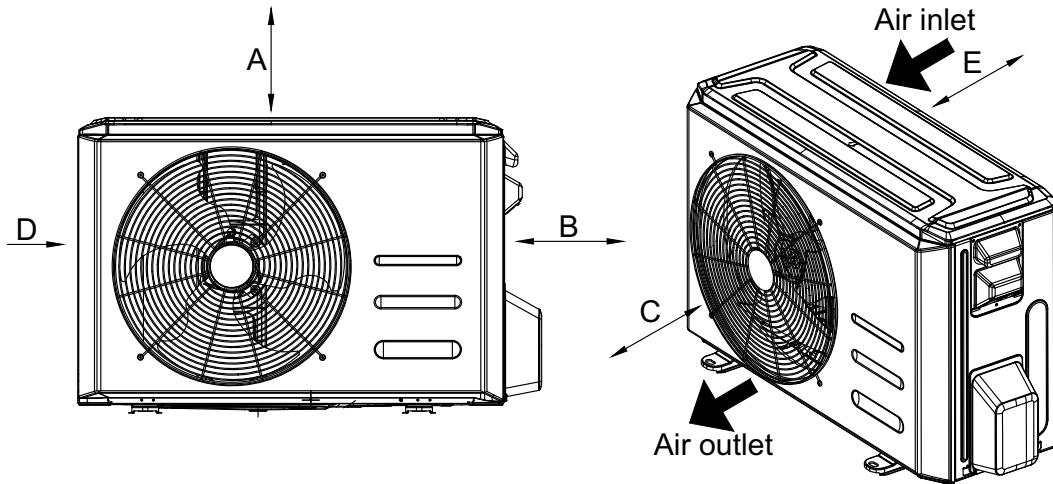

Fig. 6 — Outdoor Unit Clearances

Table 4 — Outdoor Unit Clearance Dimensions

UNIT	MINIMUM VALUE in. (mm)
A	24 (610)
B	24 (610)
C	24 (610)
D	4 (101)
E	4 (101)

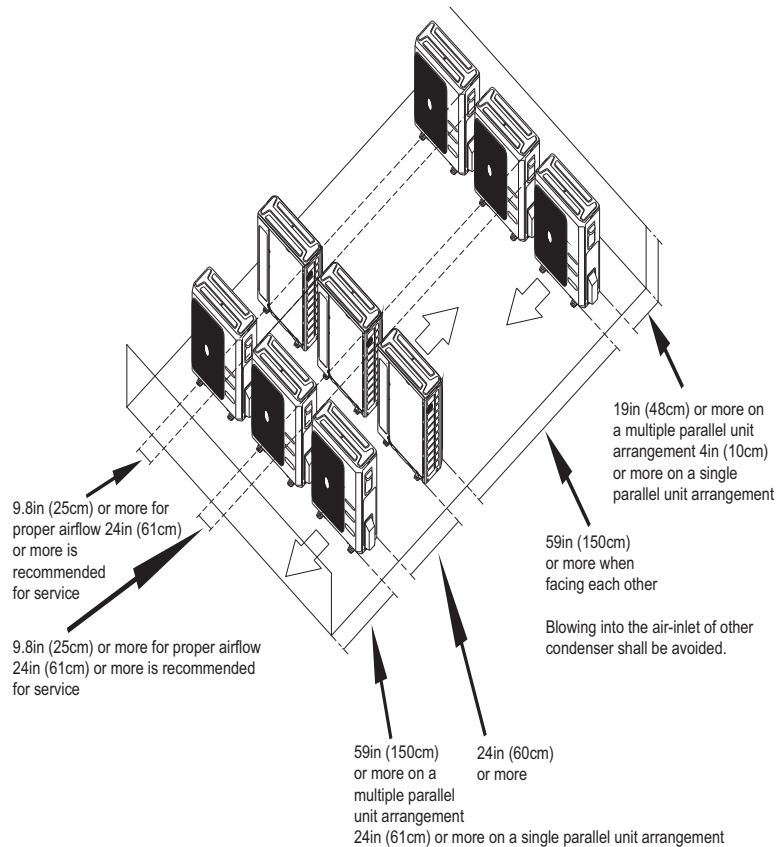

Fig. 7 —Clearances for multiple units

INSTALLATION REQUIREMENTS

- A location which is convenient to installation and not exposed to strong winds.
- A location which can bear the weight of the outdoor unit and where the outdoor unit can be mounted in a level position.
- A location which provides appropriate clearances (see Fig. 6).
- Do not install the indoor or outdoor units in a location with special environmental conditions. For those applications, contact your Sales representative.
- Allow sufficient space for airflow and service of the unit. See Fig. 6 — on page 6 for the required minimum distances between the unit or walls.

NOTE: DO NOT install the indoor or outdoor units in a location with special environmental conditions. For those applications, contact your Ductless representative.



WARNING

PRODUCT INSTALLATION

- Installation must be performed by an authorized dealer or specialist. A defective installation can cause water leakage, electrical shock, or fire.
- The installation must be performed according to the installation instructions. Improper installation can cause water leakage, electrical shock, or fire. (In North America, installation must be performed in accordance with the requirements of NEC or CEC by authorized personnel only.)
- Contact an authorized service technician for repair or maintenance of this unit. This appliance must be installed in accordance with local codes.
- Only use the included accessories, parts, and specified parts for installation. Using non-standard parts can cause water leakage, electrical shock, fire, or unit failure.
- Install drainage piping according to the instructions in this manual. Improper drainage may cause water damage to your home and property.
- **DO NOT** install the unit in a location that may be exposed to combustible gas leaks. If combustible gas accumulates around the unit, it may cause a fire.
- **DO NOT** turn on the power until all work has been completed.
- When moving or relocating the system, consult experienced service technicians for the disconnection and re-installation of the unit.

INSTALLATION

Step 1 - Check Equipment

Unpack the unit and move to the final location. Remove the carton, taking care not to damage the unit. Inspect the equipment for damage prior to installation. File a claim with the shipping company if the shipment is damaged or incomplete.

Locate the unit rating plate which contains the proper installation information. Check the rating plate to ensure the unit matches the job specifications.

Step 2 - Mount Unit

1. Select the installation location of the outdoor unit following the installation requirements. To prevent high wind exposure, install the outdoor unit with the air inlet side facing the wall (see fig 8).

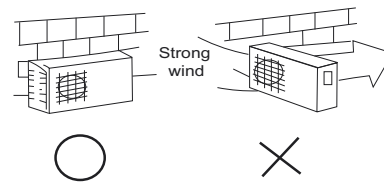

Fig. 8 — High Wind Installation

2. Use a rigid base to support the unit in a level position. If conditions or local codes require the unit be attached to a pad, tie down bolts should be used and fastened through knockouts provided in unit base pan. For hurricane tie downs, contact distributor for details and PE (Professional Engineer) Certification, if required. For extreme outdoor conditions applications refer to the 'Cold Climate Application Guideline Ductless'.



CAUTION

EQUIPMENT DAMAGE HAZARD

Failure to follow this caution may result in equipment damage or improper operation.

In regions with snowfall and cold temperatures, avoid installing the outdoor unit in areas where it can be covered by snow. Blocking the air intake may result in reduced airflow, significantly reduced performance and damage to the equipment.

Step 3 - Condensate Drain Installation

Install drains must meet local sanitation codes.

Install the outdoor unit drain joint

Fit the seal into the drain joint, then insert the drain joint into the base pan hole of the outdoor unit. Rotate 90° to securely assemble them. Connect the drain joint with an extension drain hose to avoid condensate from draining off the outdoor unit during the heating mode.

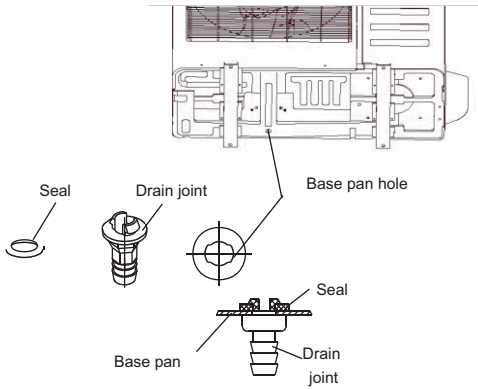

Fig. 9 —Drain Joint

NOTE: Images are for illustration purposes only.

⚠ CAUTION

EQUIPMENT DAMAGE HAZARD

In cold climates, ensure the drain hose is as vertical as possible to ensure swift water drainage. If water drains too slowly, it can freeze in the hose and flood the unit.

NOTE: Basepan built-in with multiple holes for proper draining during defrost. For applications where it is required to seal these holes, and re-direct the condensate drain, rubber plugs are available through RCD.

Table 5 — Base Pan Base Rubber Plugs

Outdoor Unit Model Number Per Unit	Base Pan Base Rubber Plugs RCD Part Number	Quantity
DLCLRCQ36AA3	12600801A00117	5
DLCLRCQ48AA3	12600801A00118	5
DLCLRCQ58AA3		

Step 4 - Refrigerant Piping

Table 6 — Piping and Refrigerant Information

SYSTEM SIZE			36K	48K	58K
PIPING	Min. Piping Length	ft (m)	10(3)	10(3)	9.8 (3)
	Standard Piping Length	ft (m)	25(7.5)	25(7.5)	24.6 (7.5)
	Max. outdoor-indoor height difference (OU higher than IU)	ft (m)	98(30)	98(30)	98.4 (30)
	Max. outdoor-indoor height difference (IU higher than OU)	ft (m)	98(30)	98(30)	98.4 (30)
	Max. Piping length with no additional refrigerant charge	ft (m)	26(8)	26(8)	24.6 (7.5)
	Max. Piping Length	ft (m)	213(65)	213(65)	213 (65)
	Additional refrigerant charge (between Standard - Max piping length)	Oz/ft (g/m)	0.32(30)	0.32(30)	0.32(30)
	Gas Pipe (size-connection type)	in (mm)	5/8(16)	5/8(16)	7/8(22)
	Liquid Pipe (size-connection type)	in (mm)	3/8(9.52)	3/8(9.52)	3/8(9.52)
REFRIGERANT	Refrigerant Type	--	R410A	R410A	R410A
	Charge Amount	Lbs (kg)	6.72(3.05)	9.26(4.2)	10.58 (4.8)

IMPORTANT: Both refrigerant lines must be insulated separately. Use refrigeration grade tubing **ONLY**. No other type of tubing may be used. Use of other types of tubing will void the manufacturer's warranty.

- All outdoor units have an electronic expansion valve to manage the refrigerant flow of the fan coil connected.
- The minimum refrigerant line length between the indoor and outdoor unit is 10 ft. (3m).
- When paired with Ductless indoor units, size the line sets based on the connection size of the indoor unit unless specified.
- Do not open the service valves or remove the protective caps from the tubing ends until all connections are made.
- Bend the tubing with bending tools to avoid kinks and flat spots.
- Keep the tubing free of dirt, sand, moisture, and other contaminants to avoid damaging the refrigerant system.
- Avoid sags in the suction line to prevent the formation of oil traps.
- Insulate each tube with a minimum 3/8-in. (10 mm) wall thermal pipe insulation. Inserting the tubing into the insulation before making the connections will save time and improve installation quality.



WARNING

All field piping must be completed by a licensed technician and must comply with the local and national regulations. When the system is installed in a small room, measures must be taken to prevent the refrigerant concentration in the room from exceeding the safety limit in the event of refrigerant leakage. If the refrigerant leaks and its concentration exceeds its proper limit, hazards due to lack of oxygen may result. When installing the refrigeration system, ensure that air, dust, moisture or foreign substances do not enter the refrigerant circuit. Contamination in the system may cause poor operating capacity, high pressure in the refrigeration cycle, explosion or injury. Ventilate the area immediately if there is refrigerant leakage during the installation. Leaked refrigerant gas is hazardous. Ensure there is no refrigerant leakage after completing the installation work.



CAUTION

DO NOT install the connecting pipe until both the indoor and outdoor units have been installed. Insulate both the gas and liquid piping to prevent condensation.

Use the following steps to connect the refrigerant piping:

1. Run the interconnecting piping from the outdoor unit to the indoor unit.
2. Connect the refrigerant piping and drain line outside the indoor unit. Complete the pipe insulation at the flare connection then fasten the piping and wiring to the wall as required. Completely seal the hole in the wall.
3. Cut tubing to the correct length.

When preparing refrigerant pipes, take extra care to cut and flare them properly. This ensures efficient operation and minimizes the need for future maintenance.

 - a. Measure the distance between the indoor and outdoor units.
 - b. Using a pipe cutter, cut the pipe a little longer than the measured distance.
 - c. Make sure the pipe is cut at a perfect 90° angle.

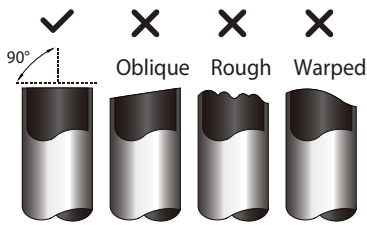

Fig. 10 — Pipe Cutting

⚠ CAUTION

DO NOT DEFORM PIPE WHILE CUTTING

Be extra careful not to damage, dent, or deform the pipe while cutting. This will drastically reduce the heating efficiency of the unit.

4. Remove Burrs

Burrs can affect the air-tight seal of the refrigerant piping connection. Therefore, they must be completely removed. To remove:

 - a. Hold the pipe at a downward angle to prevent burrs from falling into the pipe.
 - b. Using a reamer or deburring tool, remove all burrs from the cut section of the pipe.

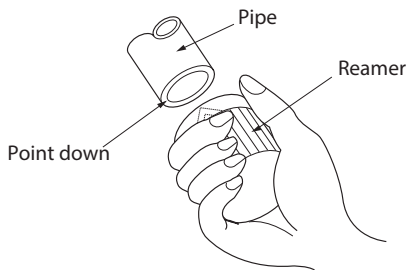

Fig. 11 — Deburring Tool

5. Flare Pipe Ends

Proper flaring is essential to achieving an airtight seal.

- a. After removing the burrs from the cut pipe, seal the ends with PVC tape to prevent foreign materials from entering the pipe.
- b. Sheath the pipe with insulating material.
- c. Place factory flare nut on pipe facing the proper direction. Make sure they are facing the right direction. Once the ends are flared, it is impossible to put them on or change their direction.

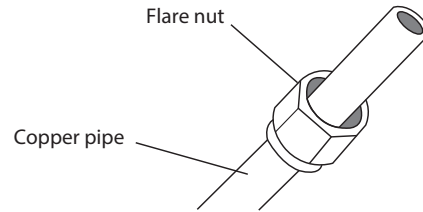

Fig. 12 — Copper pipe and flare nut

- d. Remove the PVC tape from ends of pipe when ready to perform the flaring work.
- e. Clamp the flare block on the end of the pipe. The end of the pipe must extend beyond the flare form.

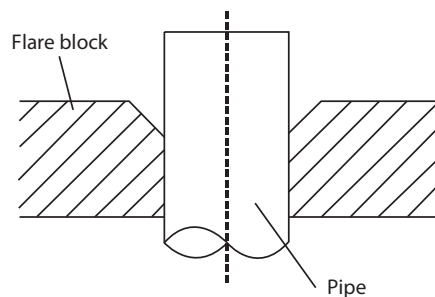

Fig. 13 — Flare Block

- f. Place the flaring tool onto the form.
- g. Turn the handle of the flaring tool clockwise until the pipe is fully flared. Flare the pipe in accordance with the dimensions in Table 14.

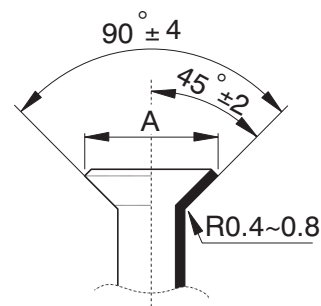

Fig. 14 — Flare Shape

- h. Remove the flaring tool and flare block, then inspect the end of the pipe for cracks and even flaring.

6. Connect the Pipes

Connect the copper pipes to the indoor unit first, then connect the pipes to the outdoor unit. Connect the low-pressure pipe first, then connect the high pressure pipe.

- a. When connecting the flare nuts, apply a thin coat of refrigeration oil to the flared ends of the pipes.
- b. Align the center of the two pipes that you will connect.

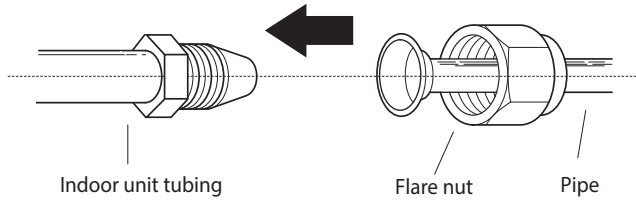

Fig. 15 — Align the center of the two pipes

- c. Tighten the flare nut as much as possible by hand.
- d. Using a wrench, grip the nut on the unit tubing.
- e. While firmly gripping the nut, use a torque wrench to tighten the flare nut according to the torque values listed in Table 7.

Table 7 — Tightening Torque

Brass Flare Size	Recommended Seating Torque For Brass Flare Nuts		Flare Dimensions (A) (inch/mm)	
			Min	Max
In (mm)	Ft-Lbs	N-M		
1/4 (6.35)	13.3-14.7	18-20	0.33/8.4	0.34/8.7
3/8 (9.52)	23.6-28.8	32-39	0.52/13.2	0.53/13.5
1/2 (12.7)	36.1-42.8	49-59	0.64/16.2	0.65/16.5
5/8 (16)	42-52.4	57-71	0.76/19.2	0.78/19.7
3/4 (19)	49.4-74.5	67-101	0.91/23.2	0.93/23.7
7/8 (22)	62.7-81.1	85-110	1.04/26.4	1.06/26.9

NOTE: Use both a backup wrench and a torque wrench when connecting or disconnecting pipes to or from the unit.

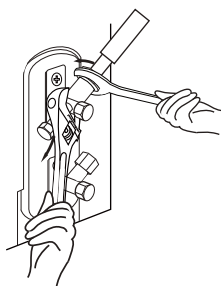

Fig. 16 — Torque wrench with backup wrench

All tubing bends should be performed with a properly sized tubing bender to prevent kinking or damaging the tubing.

- f. After connecting the copper pipes to the indoor unit, wrap the power cable, signal cable and the piping together with binding tape.

NOTE: While bundling these items together, DO NOT intertwine or cross the signal cable with any other wiring.

- g. Thread this lineset through the wall and connect it to the outdoor unit.
- h. Insulate all piping, including the outdoor unit valves.

NOTE: DO NOT open the service valves until pressure test is complete.

7. Pressure Test Piping

⚠ CAUTION

Only use Dry Nitrogen to pressure test refrigerant systems. Use of other gases can result in injury, property damage or death.

NOTE: Use refrigeration gauges that are pressure rated for R410a refrigerant.

- a. Attach low side gauge hose to the 5/16” Schrader valve on the outdoor unit service valve.
- b. Attach the charging hose to the regulator on the dry nitrogen tank.
- c. Preset the nitrogen regulator to 550 psi.
- d. Slowly pressurize the line set until the low side gauge reads 500 psi. Do not exceed 550 psi.
- e. Close all the valves on the nitrogen tank and gauges.
- f. Allow the pressure test to stand for a minimum of 30 minutes.
- g. If the pressure holds, release the nitrogen and proceed with See “Step 5 - Evacuate Coil And Tubing System” on page 12..
- h. If the pressure goes down in the 30 minute delay, leak check the tubing and flare fittings to identify the source of the leak. Return to Step C, above.

⚠ CAUTION

Wrap insulation around the piping. Direct contact with the bare piping may result in burns or frostbite. Ensure the pipe is properly connected. Over tightening may damage the bell mouth and under tightening may lead to leakage.

Step 5 - Evacuate Coil And Tubing System

CAUTION

UNIT DAMAGE HAZARD

Failure to follow this caution may result in equipment damage or improper operation.

Never use the system compressor as a vacuum pump.

Refrigerant tubes and the indoor coil should be evacuated using the recommended 500 microns deep vacuum method. The alternate triple evacuation method may be used if the procedure outlined below is followed.

NOTE: Always break a vacuum with dry nitrogen.

Using Vacuum Pump

1. Completely tighten flare nuts A, B, C, D. Connect the manifold gage charge hose to a charge port of the low side service valve (see Fig. 17).
2. Connect the charge hose to vacuum pump.
3. Fully open the low side of manifold gage (see Fig. 18).
4. Start the vacuum pump.
5. Evacuate using either the deep vacuum or triple evacuation method.
6. After evacuation is complete, fully close the low side of manifold gage and stop the vacuum pump operation.
7. The factory charge contained in the outdoor unit is good for up to 25 ft. (8 m) of line length. For refrigerant lines longer than 25 ft. (8 m), add refrigerant, up to the allowable length.
8. Disconnect the charge hose from the charge connection of the low side service valve.
9. Fully open service valves B and A.
10. Securely tighten the service valve caps.

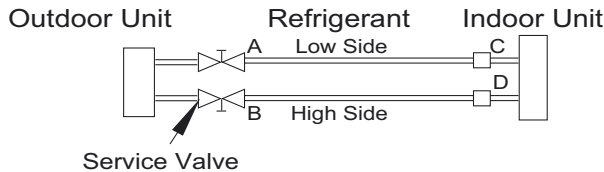

Fig. 17 — Service Valve

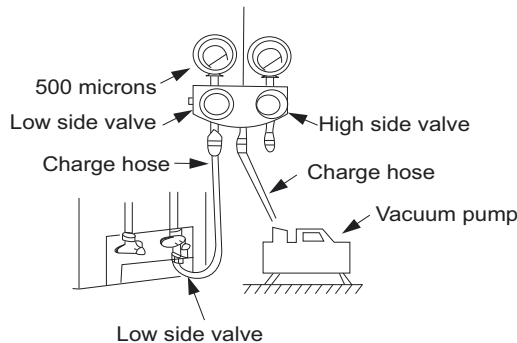

Fig. 18 — Manifold

Evacuation

Evacuation of the system will remove air or nitrogen (non-condensables) as well as moisture. A proper vacuum will assure a tight, dry system before charging with refrigerant. The two methods used to evacuate a system are the deep vacuum method and the triple vacuum method.

Deep Vacuum Method

The deep vacuum method requires a vacuum pump capable of pulling a vacuum of 500 microns and a vacuum gauge capable of accurately measuring this vacuum depth. The deep vacuum method is the most positive way of assuring a system is free of air and moisture (see Figure 19).

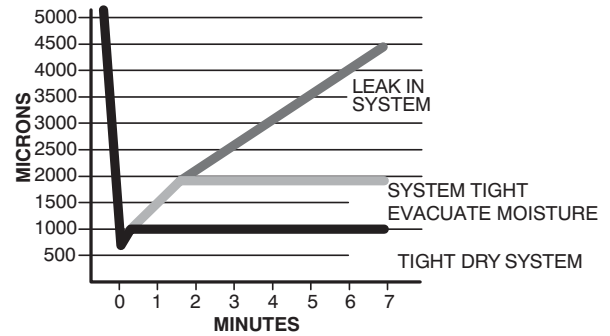

Fig. 19 — Deep Vacuum Graph

Triple Evacuation Method

The triple evacuation method should be used when vacuum pump is not capable of pumping down to 500 microns and system does not contain any liquid water. Refer to Fig. 20 and proceed as follows:

1. Attach refrigeration gauges and evacuate system down to 28 in. of mercury and allow pump to continue operating for an additional 15 minutes.
2. Close service valves and shut off vacuum pump.
3. Connect a nitrogen cylinder and regulator to system and flow nitrogen until system pressure is 2 psig.
4. Close service valve and allow system to stand for 1 hour. During this time, dry nitrogen will be able to diffuse throughout the system absorbing moisture.
5. Repeat this procedure as indicated in Fig. 20. System will then be free of any contaminants and water vapor.

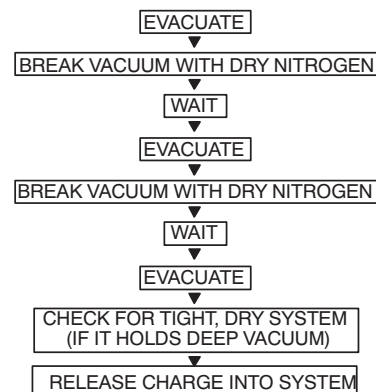

Fig. 20 — Triple Evacuation Method

Final Tubing Check

Check to be certain factory tubing on both the indoor and outdoor unit has not shifted during shipment. Ensure tubes are not rubbing against each other or any sheet metal. Pay close attention to the feeder tubes, making sure wire ties on feeder tubes are secure and tight.

Step 6 - Electrical Connections

Install All Power and Interconnecting Wiring to Outdoor Units

1. Mount the outdoor power disconnect.
2. Run the power wiring from the main box to disconnect per NEC and local codes.
3. Remove the field wiring cover from the unit by loosening the screws.
4. Remove the caps on the conduit panel.
5. Connect the conduit to conduit panel (see Fig.21).
6. Properly connect both the power supply and control lines to the terminal block per the connection diagram for the appropriate unit capacity and voltage.
7. Ground the unit in accordance with NEC and local electrical codes.
8. Use the lock nuts to secure the conduit.
9. Reinstall the field wiring cover.

WIRING

All wires must be sized per NEC (National Electrical Code) or CEC (Canadian Electrical Code) and local codes. Use Electrical Data table MCA (minimum circuit amps) and MOCP (maximum over current protection) to correctly size the wires and the disconnect fuse or breakers respectively.

SIZES 36-58 RECOMMENDED CONNECTION METHOD FOR POWER AND COMMUNICATION WIRING

Power and Communication Wiring: The main power is supplied to the outdoor unit. The field supplied power wiring from the outdoor unit to the indoor unit consists of three (3) wires and provides the power for the indoor unit. Two wires are high voltage AC power and one is a ground wire. To minimize voltage drop, the factory recommended wire size is 14/2 stranded with a ground.

Communication Wiring: A separate shielded stranded copper conductor only, with a 600 volt rating and double insulated copper wire, must be used as the communication wire from the outdoor unit to the indoor unit. Please use a separate shielded 16GA stranded control wire.

Table 8 — Wiring Sizes 36-58

Cable	Cable Size	Remarks
Power Connection Cable	14AWG	2 wire + Ground 1Φ 208/230 V
Communication Cable	16AWG	2 wire stranded shielded control wire

⚠ **CAUTION**

EQUIPMENT DAMAGE HAZARD

Failure to follow this caution may result in equipment damage or improper operation.

Be sure to comply with local codes while running wire from indoor unit to outdoor unit.

Every wire must be connected firmly. Loose wiring may cause the terminal to overheat or result in unit malfunction. A fire hazard may also exist. Therefore, ensure all wiring is tightly connected.

No wire should be allowed to touch the refrigerant tubing, compressor or any moving parts.

Disconnecting means must be provided and shall be located within sight and readily accessible from the air conditioner.

Connecting cable with the conduit shall be routed through hole in the conduit panel.

⚠ **WARNING**

EQUIPMENT DAMAGE HAZARD

Failure to follow this caution may result in equipment damage or improper operation. Wires should be sized based on NEDC and local codes.

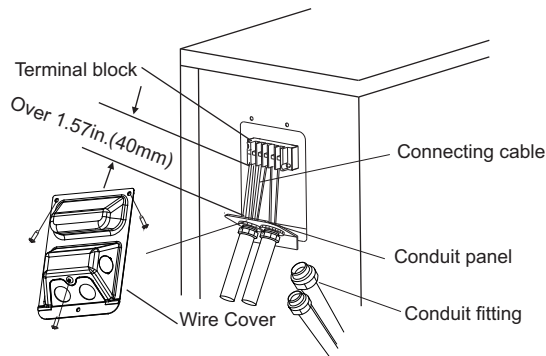

Select the appropriate conduit opening for the wire size used.

Fig. 21 —Field Wiring

⚠ **CAUTION**

EQUIPMENT DAMAGE HAZARD

Failure to follow this caution may result in equipment damage or improper operation. Be sure to comply with local codes while running wire from the indoor unit to the outdoor unit. Every wire must be connected firmly. Loose wiring may cause the terminal to overheat or result in unit malfunction. A fire hazard may also exist. Ensure all wiring is tightly connected.

No wire should touch the refrigerant tubing, compressor or any moving parts. Disconnecting means must be provided and shall be located within sight and readily accessible from the air conditioner. Connecting cable with conduit shall be routed through the hole in the conduit panel.

⚠ **WARNING**

An approved and listed fitting must be used to securely affix conduit in accordance with NEC and local codes.

ELECTRICAL DATA

Table 9 — Electrical Data

OUTDOOR UNIT SIZE		36K	48K	58K
Power Supply		208/230 - 1 - 60	208/230 - 1 - 60	208/230 - 1 - 60
	Max – Min* Oper. Voltage	253 - 187	253 - 187	253 - 187
	MCA	30	39	42
	MOCP	45	50	60
Compressor	Volts- PH- Hz	208/230 - 1 - 60	208/230 - 1 - 60	208/230 - 1 - 60
	Rated Current (RLA)	22	23.5	25
Outdoor Fan Motor	FLA	1.21	1.17	1.5
	Rated HP	0.16	0.14	0.11
	Output	120	85	85

*Permissible limits of the voltage range at which the unit will operate satisfactorily.

LEGEND

- FLA - Full Load Amps
- MCA - Minimum Circuit Amps
- MOCP - Maximum Over-Current Protection
- RLA - Rated Load Amps

CONNECTION DIAGRAMS

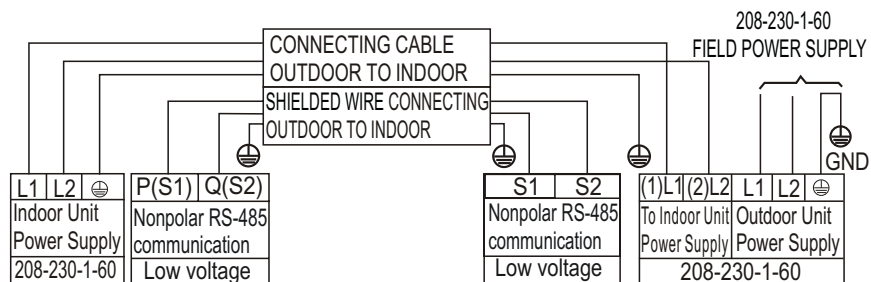

Fig. 22 — Connection Diagram Sizes 36K - 58K

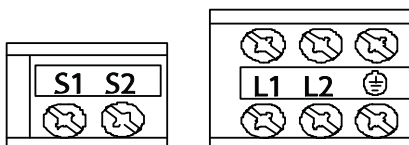

Fig. 23 — Control and Power Terminals on Indoor Unit Sizes 36K - 58K

NOTES:

- Do not use the thermostat wire for any connection between indoor and outdoor units.
- All connections between indoor and outdoor units must be as shown in Figure 22. The connections are sensitive to polarity and will result in a fault code.

START-UP

Test Operation

Perform a test operation after completing a gas leak and electrical safety check. See the indoor unit installation instructions and owner's manual for additional start up information.

System Checks

1. Conceal the tubing where possible.
2. Ensure the drain tube slopes downward along its entire length.
3. Ensure all tubing and connections are properly insulated.
4. Fasten the tubes to the outside wall, when possible.
5. Seal the hole through which the cables and tubing pass.

OUTDOOR UNIT DIAGNOSTIC GUIDES

For ease of service, the systems are equipped with a diagnostic code display LEDs on both the indoor and outdoor units. The outdoor diagnostic is displayed on the outdoor unit microprocessor board. There may be a few error codes displayed in the indoor unit that might relate to the outdoor unit's problems. If possible, always check the diagnostic codes displayed on the indoor unit first. The diagnostic codes displayed on the outdoor units are listed on Table 10.

Table 10 — Unit Diagnostic Guides

DISPLAY	LED STATUS
EL01	Communication malfunction between the indoor and outdoor units
EC50	Outdoor temperature sensor error
EC51	Outdoor EEPROM error
EC52	Condenser coil temperature sensor (T3) malfunction
EC53	Outdoor ambient temperature sensor (T4) malfunction
EC54	Compressor discharge temperature sensor TP is on open circuit or has short circuited
EC55	Outdoor IPM module temperature sensor malfunction
EC07	Outdoor DC fan motor malfunction/fan speed out of control
EC71	Over current failure of the outdoor DC fan motor
EC72	Lack phase failure of the outdoor DC fan motor
PC00	Inverter module (IPM) protection
PC02	Top temperature protection of compressor
PC06	Discharge temperature protection of compressor
PC08	Outdoor overcurrent protection
PC0A	High temperature protection of condenser
PC0F	PFC module protection
PC0L	Low temperature protection of the outdoor unit
PC10	Outdoor unit low AC voltage protection
PC11	Outdoor unit main control board DC bus high voltage protection
PC12	Outdoor unit main control board DC bus high voltage protection /341 MCE error
PC30	System high pressure protection
PC31	System low pressure protection
PC40	Communication error between the outdoor main chip and compressor driven chip
PC42	Compressor start failure of the outdoor unit
PC43	Outdoor compressor lack phase protection
PC44	Outdoor unit zero speed protection
PC45	Outdoor unit IR chip drive failure
PC46	Compressor speed has been out of control
PC49	Compressor overcurrent failure
PH90	High temperature protection of the evaporator
PH91	Low temperature protection of the evaporator
LC06	High temperature protection of the inverter module (IPM)

For additional diagnostic information, refer to the service manual.

Outdoor Unit

Are there unusual noises or vibrations during operation?

Explain the Following Item to the Customer (with the aid of the Owner's Manual):

- Explain unit care and maintenance.

IMPORTANT: Present the installation instructions to the customer.

CARE AND MAINTENANCE

To help ensure high performance and minimize possible equipment failure, periodic maintenance must be performed on this equipment.

Maintenance frequency may vary depending upon geographic areas.

DUCTLESS START-UP CHECKLIST

Installation Data

Site Address: _____

City: _____ State: _____ Zip Code: _____

Installing Contractor: _____ Contractor Contact #: () _____ - _____

Job Name: _____ Start-up Date: _____

Distributor: _____

System Details

Units	Model No.	Serial No.	Controller
OUTDOOR UNIT			
INDOOR UNIT A			

Wiring Electrical

Wire Size and Type Used? AWG: _____ TYPE: _____

Are there any breaks, splices, wire nuts or butt connectors between the outdoor unit and the indoor door unit? YES: _____ NO: _____

Was the wiring from the outdoor unit port to the correct indoor unit verified? YES: _____ NO: _____

REMARKS: _____

Voltage Check

Wiring: Single zone _____

Outdoor Unit Disconnect	1(L1):GND		Outdoor Unit Terminal Block	1(L1):GND		NOTES: _____ _____ _____ _____	
	2(L2):GND			2(L2):GND			
	1(L1):L2(2)			1(L1):2(L2)			
Indoor Unit Voltage Check @ Outdoor Unit	1(L1):GND		Indoor Unit Voltage Check @ Indoor Unit	1(L1):GND			NOTES: _____ _____ _____ _____
	2(L2):GND			2(L2):GND			
	1(L1):2(L2)			1(L1):2(L2)			
	2(L2):3(S)			2(L2):3(S)			

Ductless Start-Up Checklist (CONT)

Piping

Leak Check:

System held 500 psig (max. 550psi) for a minimum of 30 minutes using dry nitrogen. YES: _____ NO: _____

Evacuation Method:

- Was the Triple Evacuation Method used as outlined in the installation manual? YES: _____ NO: _____
- Was the Deep Vacuum Method used as outlined in the installation manual? YES: _____ NO: _____
- Did the System Hold 500 microns for 1 hour? YES: _____ NO: _____
- Does the line set match the diameter of the evaporator connections? YES: _____ NO: _____

Single Zone Piping:

Has the liquid pipe length been measured and the additional charge calculated? Size: _____ Length: _____ Charge: _____

Notes:

PORT	LIQUID SIZE	SUCTION SIZE	LENGTH	CHARGE	NOTES:
A					

Performance Check

For 1:1 Single Zone Systems: Adjust the set-point to create an operational call for the desired testing operation. Allow the system to run for a minimum of 10 min. and record the following details:

(Operational data recorded on applicable heads with the wireless remote controller's Point Check function)

UNIT	SET-POINT	MODE	T1	T2	T3	T4	Tb	Tp	Th	LA/Lr
A										

Error Codes

Were there any error codes present at start-up? YES: _____ NO: _____

Indoor Unit Error Code:		Notes:
Outdoor Unit Error Code:		
Wall Controller:		
24V Interface:		

Comments:
